

Terminal Dimensions

GT-F Range

(Front Terminal) is recognised worldwide as the premium battery for telecommunications/IT applications. GT-F range reputation for long service life, combined with excellent high rate performance, also it the number one choice for high integrity, high specification UPS systems. GT-F front terminal monoblock's compact design and standard footprint, suitable for 19", 21" 23" ans ETSI racking, give users the benefit of increased energy density, with all electrical connector at the front, installation and inspection are simpler and quicker

Application

- Telecom
- Control Equipment
- UPS
- Communication Equipment
- Medical Equipment
- Emergency Power System

General Features

- Easy maintenance and installation
- No need for extra (wrench space) above battery
- Sealed and maintenance free operation
- Non-Spillable construction design
- ABS containers and covers (UL94HB, UL94V-0) optional
- Safety valve installation for explosion proof
- Maximized energy density for installation in relay rack trays
- High quality and high reliability
- Exceptional deep discharge recovery performance
- Flexibility design for multiple install positions

Construction

- ComponentRaw material
- PositiveLead dioxide
- NegativeLead
- ContainerABS
- CoverABS
- SealantEpoxy Resin
- Safety valveEPDR
- TerminalCopper
- SeparatorFiber glass
- ElectrolyteSulfuric acid

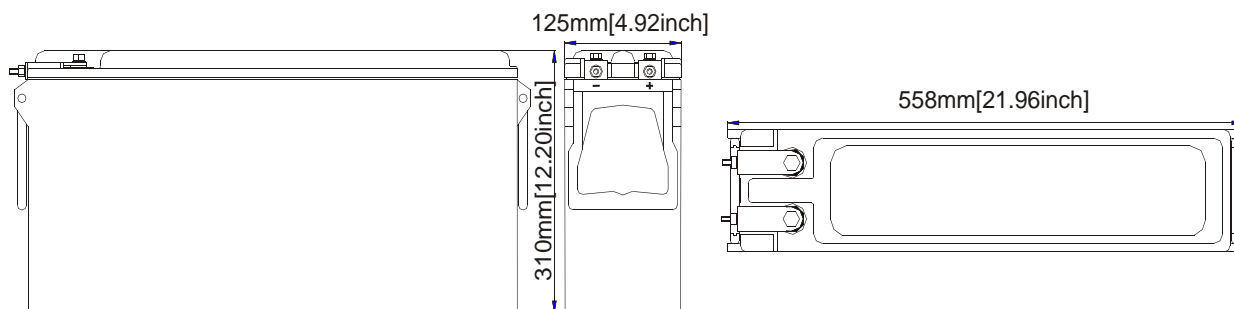

Battery Model	GT12-150F			
Designed Floating Life	12 Years			
Capacity(25°C)	20HR(8.20A,1.75V)	10HR(15.1A,1.75V)	5HR(26.5A,1.75V)	1HR(85A,1.75V)
	164AH	151AH	132.5AH	85AH
Dimensions	Length	Width	Height	Total Height
	558mm(21.96inch)	125mm(4.92inch)	310mm(12.20inch)	310mm(12.20inch)
Approx. Weight	57.0Kg (125.4 lbs)			
Internal Resistance	Full charged at 25°C :0.00371 Ohm			
Self Discharge	3% of capacity declined per month at (25°C)			
Capacity Affected by Temp.(20HR)	40°C	25°C	0°C	-15°C
	102%	100%	85%	65%
Charge Voltage(25°C)	Cycle use		Float use	
	14.4-14.8V(-30mV/ °C), max. Current: 37.50A		13.6-13.8(-20mV/ °C)	

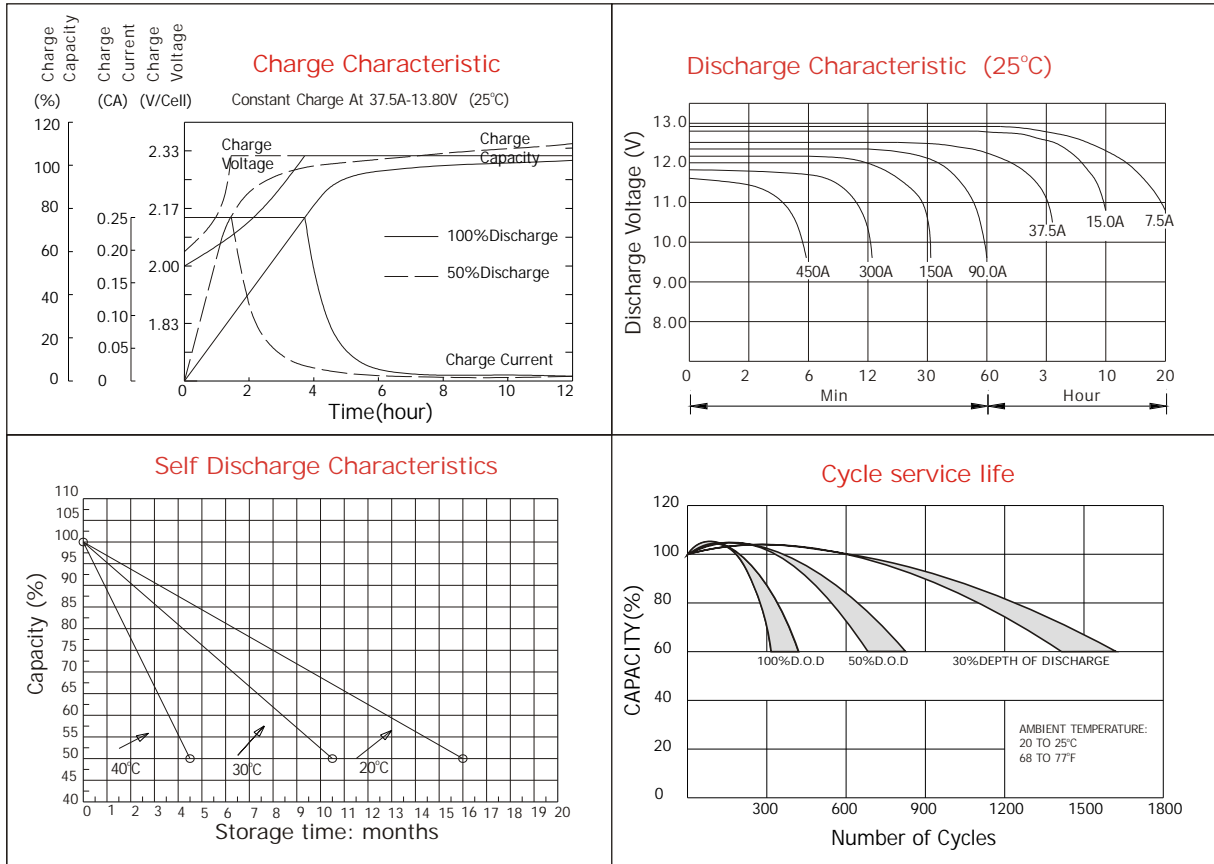

Constant current discharge ratings-amperes at 25°C

F. V/Time	5MIN	15MIN	30MIN	1HR	3HR	5HR	8HR	10HR	20HR
1.60V	503	258	155	92	42.0	27.6	18.5	15.5	8.50
1.67V	458	243	152	89	41.3	27.2	18.1	15.3	8.35
1.70V	443	237	150	88	41.0	27.0	18.0	15.2	8.30
1.75V	399	225	147	85	40.2	26.5	17.9	15.1	8.20
1.80V	360	213	143	82	39.0	25.8	17.8	15.0	8.10
1.85V	318	198	135	75	37.8	25.0	17.3	14.7	8.00

Constant power discharge ratings-watts at 25°C

F. V/Time	5MIN	15MIN	30MIN	1HR	3HR	5HR	8HR	10HR	20HR
1.60V	679	397	262	153	75.3	51.2	35.0	27.8	14.8
1.67V	673	394	260	151	74.6	50.5	34.7	27.5	14.6
1.70V	671	393	259	150	74.3	50.3	34.5	27.3	14.5
1.75V	663	390	257	148	73.7	50.0	34.0	27.2	14.3
1.80V	648	383	255	146	72.8	49.5	33.7	27.0	14.2
1.85V	588	369	246	139	69.8	48.3	33.0	26.3	13.8

