



AGM and Gel

Range batteries uses the advanced GEL design which combines the best features of AGM and GEL construction into one battery line, and the purity fumed silica to form sulfuric acid thixotropic Gel and fills to the batteries with vacuum to ensure the fully penetration of electrolyte through separators and plates pastes.

This range battery are designed to meet the requirement of frequent cyclic and high temperature application such as boardband, PVs etc.

Application

Broadband
Electric Powered Vehicles
UPS
Photovoltaic & Solar system

Electric Powered Toys
Control System
Vacuum Cleaners
Medical Equipments
Golf Cars and Buggies
Wheel Chairs

General Features

Ideal for cyclic uses
Good tolerance to higher temperature applications.
ABS containers and covers(UL94HB, UL94V-0) optional.
Safety valve installation for explosion proof.
Higher safety & reliable construction.
Extra durability and deep cycle ability for heavy demand applications.
Low self discharge characteristic.
Good tolerance to higher temperature applications.

Construction

ComponentRaw material
PositiveLead dioxide
NegativeLead
ContainerABS
CoverABS

SealantEpoxy Resin
Safety valveEPDR
TerminalLead
SeparatorAGM
Electrolytesulfuric acid
thixotropic Gel

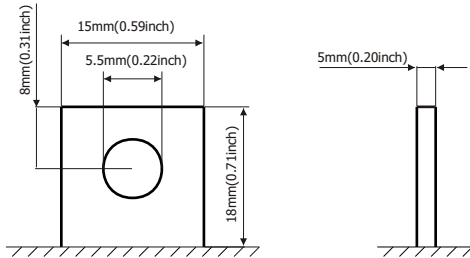

Standard Terminal Dimensions
(Optional terminal please check terminal information page)

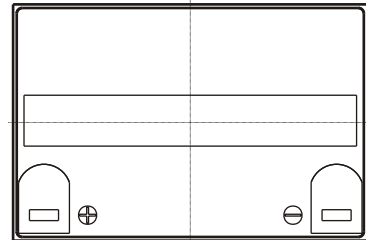
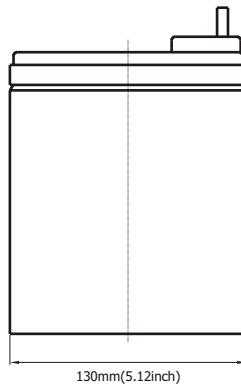
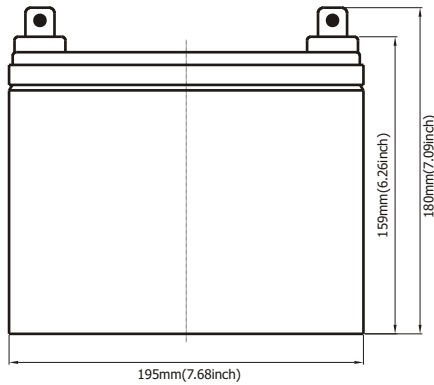

Battery Model	GT12-35AG			
Designed Life	10 Years (Floating) or > 750 Cycles @ 50% D.O.D			
Capacity(25°C)	20HR(1.75A,1.75V)	10HR(3.3A,1.75V)	5HR(5.5A,1.75V)	1HR(19.8A,1.75V)
	35AH	33AH	27.5AH	19.8AH
Dimensions	Length	Width	Height	Total Height
	195mm(7.68inch)	130mm(5.12inch)	159mm(6.26inch)	180mm(7.09inch)
Approx. Weight	11Kg (24.3 lbs)			
Internal Resistance	Full charged at 25°C: 0.01 Ohm			
Self Discharge	3% of capacity declined per month at (25°C)			
Capacity Affected by Temp.(20HR)	40°C	25°C	0°C	-15°C
	102%	100%	85%	65%
Charge Voltage(25°C)	Cycle use		Float use	
	14.4-15V(-30mV/ °C), max. Current: 8.75A		13.6-13.8V(-20mV/ °C)	

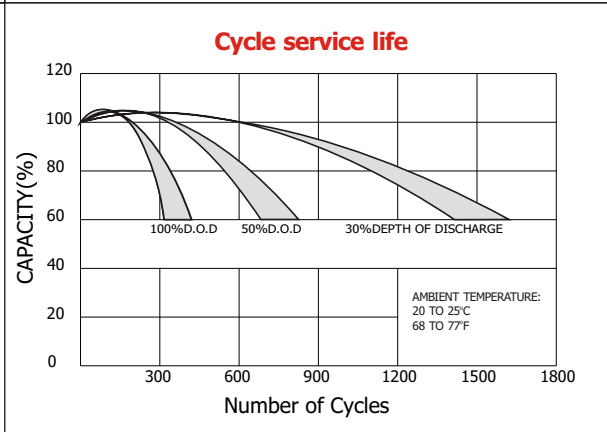
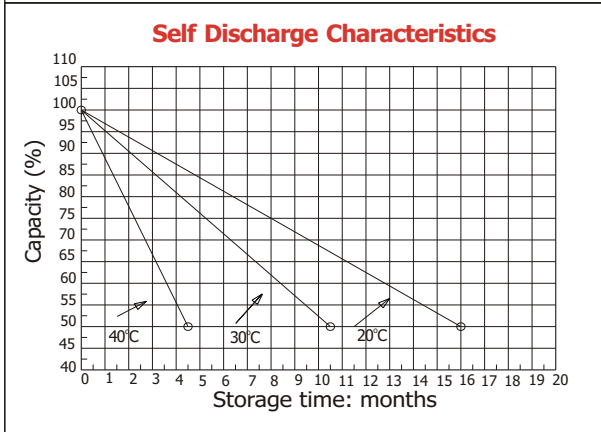
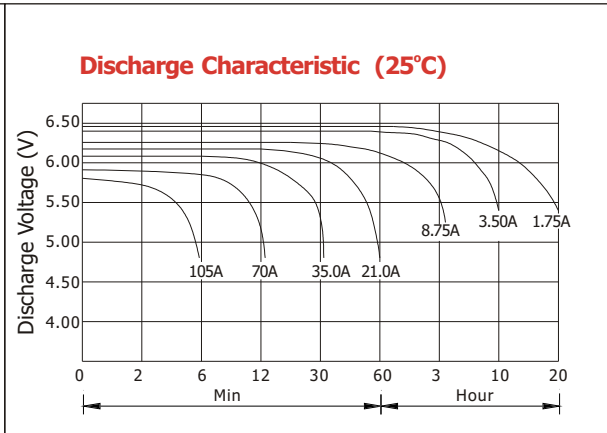
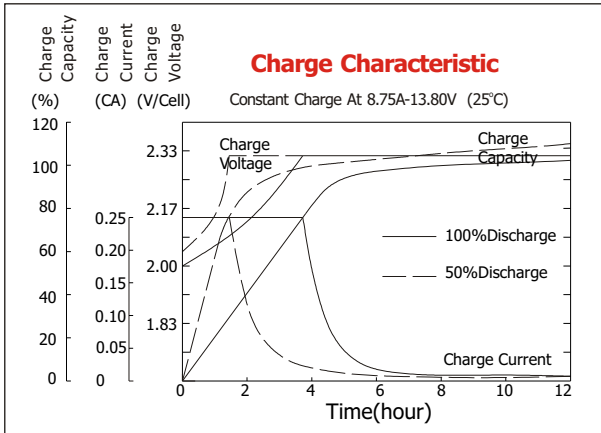

Constant current discharge ratings-amperes at 25°C

F. V/Time	5MIN	10MIN	15MIN	30MIN	1HR	3HR	5HR	10HR	20HR
1.60V	116	79.2	57.8	34.7	21.8	9.01	6.30	3.50	1.77
1.67V	104	72.3	56.1	33.7	21.7	8.98	6.24	3.45	1.76
1.70V	98.7	69.6	54.1	33.0	21.7	8.98	6.24	3.42	1.76
1.75V	87.8	64.4	51.2	32.3	21.5	8.91	6.19	3.36	1.75
1.80V	79.2	59.7	48.8	31.4	21.2	8.88	6.14	3.30	1.69
1.85V	60.1	49.2	42.2	28.8	21.0	8.84	6.09	3.24	1.59

Constant power discharge ratings-watts at 25°C

F. V/Time	5MIN	10MIN	15MIN	30MIN	1HR	3HR	5HR	10HR	20HR
1.60V	190	131	102	65.3	42.9	17.3	12.0	7.00	3.53
1.67V	181	130	101	64.0	41.5	17.3	12.0	6.89	3.52
1.70V	169	126	99.7	62.4	40.4	17.3	12.0	6.84	3.52
1.75V	157	118	93.7	60.7	40.0	17.0	11.9	6.72	3.50
1.80V	141	110	88.1	59.1	39.3	16.8	11.7	6.61	3.38
1.85V	113	91.1	76.9	54.1	39.0	16.7	11.6	6.49	3.18

